

Infrared Hydrocarbon Gas Detector

AutoPoint HC200

Features

- Superior optics protection system.
- No undisclosed failure modes.
- Routine calibration not required.
- Explosion-proof, stainless steel housing with tethered weather protection baffle.
- Integral wiring compartment eliminates need for external junction boxes.
- Built-in tri-colour LED eliminates need for external display module.
- Built-in optional relay package eliminates need for external relay output module.
- Optional hand-held HART communicator enables field configuration and calibration.
- Heated sapphire optics deliver long-lasting, high-performance detection capability.
- Immune to damage from exposure to constant background gases or to high gas concentrations.
- CENELEC and CE (including ATEX 94/9/EC) certifications.
- Certified to CENELEC EEx d, e protection standards for maximum versatility.

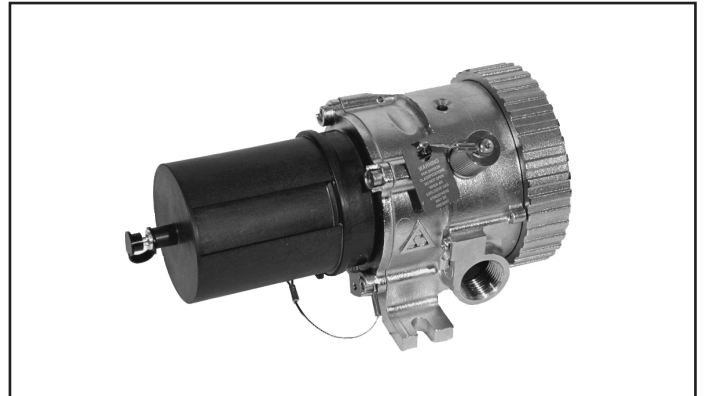

Application/Description

The AutoPoint HC200 is a diffusion-based, infrared combustible gas detector that provides continuous, fixed monitoring of flammable hydrocarbon gases from 0 to 100% Lower Explosive Limit (LEL). Standard device outputs include an electrically isolated 4 to 20 mA signal with HART communication protocol, and RS-485 serial communication. Serial communication protocols supported include MODBUS and ASCII.

Ideally suited for protection of challenging on/offshore oil and gas facilities and other downstream hydrocarbon applications, the AutoPoint HC200 is certified for use in hazardous areas Zone 1 and Zone 2. In addition, the stainless steel construction, sapphire optics, and modular design all combine to deliver industrial grade hardness along with easy installation and the lowest cost of ownership available.

The AutoPoint HC200 is capable of detecting hundreds of flammable hydrocarbon vapours. Field-selectable algorithms are provided for methane (default), ethane, propane, butane, ethylene, and propylene. Numerous additional operating parameters are programmable via digital communications or the optional hand-held communicator.

Technical specifications

Input Voltage	24 VDC nominal. Operating range is 18 to 32 VDC including ripple.		
Power Consumption	4.0 watts nominal @ 24 VDC 7.5 watts maximum @ 24 VDC 10 watts maximum @ 32 VDC.		
Short Circuit Current	Isc:	5.4 amperes.	
	Isc (fuse):	3.1 amperes.	
Warmup Time	Two minutes from cold power-up to normal mode; 1 hour minimum recommended.		
Current Output	Linear 4 to 20 mA (current source/sink, isolated/non-isolated) rated at 600 ohms maximum loop resistance @ 24 VDC operating voltage.		
Detection Range	0 to 100% LEL standard. Other ranges are configurable.		
Detectable Gases	Most flammable hydrocarbon vapours are detectable. Standard gases include methane, ethane, ethylene, propane, butane and propylene. Detection of non-standard gases is configurable using the HC275 HART communicator.		
Calibration	All units are methane-calibrated at the factory. Device configuration is required for detection of vapours other than methane.		
Device Configuration	Configuration parameters include tag number, measurement range, signal processing algorithm, alarm levels, and other selectable parameters.		
Response Time (With Baffle Installed)		T50	T60
	Without Hydrophobic Filter:	3	4
	With Hydrophobic Filter:	6	7
		T90	12
Temperature Range	Operating: -40°C to +75°C (-40°F to +167°F). Storage: -55°C to +85°C (-67°F to +185°F).		
Humidity (non-condensing)	0 to 99% R.H. 5 to 95% R.H. (FM/CSA/CENELEC verified).		
Alarm Setpoint Range	Low Alarm: 5 to 60% LEL High Alarm: 5 to 60% LEL.		
Accuracy	±3% from 0 to 50% LEL, ±5% from 51 to 100% LEL.		
Self-Diagnostic Test	All critical tests performed once per second.		
Ingress Protection	IP66 (CENELEC Verified).		
Detector Housing Material	CF8M stainless steel.		
Conduit Entry Options	Two entries, 25 mm.		
HART Communicator Port	Intrinsically safe (CENELEC/CE).		

Optics Protection Weather baffle assembly is Polythalamide plastic, UV-resistant, static dissipating black. Optional internal hydrophobic filter recommended for areas with high levels of airborne particulates or humidity.

Visual Status Indicator Tri-colour LED: Red = alarm
Green = power on / OK
Yellow = fault.

Wiring Terminals Field wiring screw terminals are UL/CSA rated for 14 to 24 AWG wire, and are DIN/VDE rated for 2.5 mm² wire. Screw terminal required torque range is 0.4-0.5 N-m. Wiring compartment is rated Increased Safety (EEx e).

Certifications CENELEC: DEMKO 01 ATEX 129485X.
EEx d e [ib] IIC T6
(Tamb -40°C to +40°C)
EEx d e [ib] IIC T5
(Tamb -40°C to +50°C)
EEx d e [ib] IIC T4
(Tamb -40°C to +75°C).
IP66.



Intrinsically Safe HART Port:
U_o = 4.0 V
I_o = 100 mA
C_o = 20 µF
L_o = 500 nH.



CE: Conforms to:
Low Voltage Directive: 73/23/EEC,
EMC Directive: 89/336/EEC,
ATEX Directive: 94/9/EC.

Shipping Weight 7.5 pounds (3.4 kg).

Dimensions

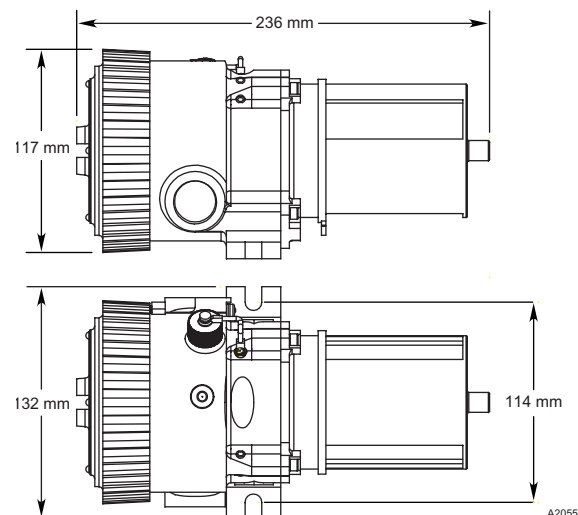

Order number	Description
5861-011.5100	AutroPoint HC200 EEx d e 4-20mA output
5861-011.5200	AutroPoint HC200 EEx d Relay output

Autronica Fire and Security AS

Autronica Fire and Security, Trondheim, Norway. Phone: (+ 47) 73 58 25 00, fax: (+ 47) 73 58 25 01.

Oil & Gas, Stavanger, Norway. Phone: (+ 47) 51 84 09 00, fax: (+ 47) 51 84 09 99.

Visit Autronica Fire and Security's Web site: www.autronicafire.com